

TR **SPRING BRAKES**
INDUSTRY STANDARD



TR-3030
Model Shown

**Overwhelming
Choice of
NORTH
AMERICAN
Truck &
Trailer
OEMs**



MGM Brakes

Form No. 5019

TR Model Spring Brakes

Our **TR** models are standard equipment on many vehicles manufactured by leading North American truck and trailer OEMs. Advanced design and superior engineered materials add up to unparalleled durability and reliable performance, year after year. A wide array of sizes (20-36) are available to suit any need. Our **TR-Series** has become so popular over the years that today it is the industry's spring brake standard.

NOTE: Special feature TR models are also offered including units with external breather tubes to seal out contaminants (**TR-T**), heavy-duty power springs for extra parking force (**TR-HD**), epoxy-coatings to reduce corrosion (**TR-TS**) and 3-inch Long Stroke design for increased performance (**TR-LP3**).

KEY FEATURES

- Patented, permanently sealed spring chamber for safety
- Centerhole shield protects against contaminants and eliminates the need for dust boots
- Stroke Alert indicator reveals when brake service may be required
- Epoxy-coated non-pressure and spring chambers, double-coated power spring, and 360 aluminum alloy center case provide durable, lasting corrosion protection
- Self-retained dust plug and side-mounted release tool storage pocket for convenience
- Extra-strength mounting hardware with self-locking fasteners ensures dependable installation
- Polymer push-rod guides last longer
- Molded nitrile rubber push-rod air seal retains lubricant better for longer-lasting protection against air leaks
- Patented, low-friction piston and guide design ensures proper alignment to maintain higher efficiency and smoother operation of spring brake
- Heavy-duty nylon-reinforced diaphragms are formulated to perform efficiently in cold weather conditions
- Long life lubricants for brake longevity

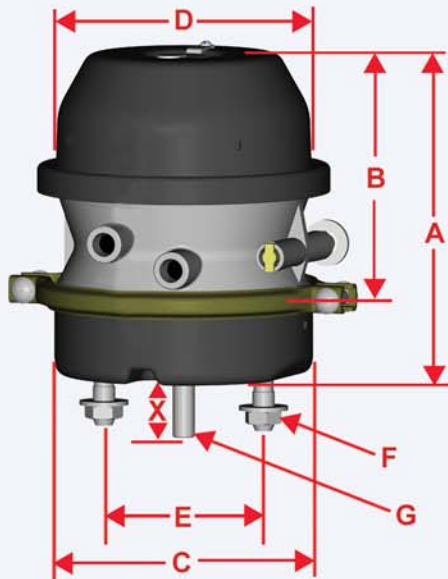

TR3030
Model Shown

P/N Series	3420	3427	3429	3434	3430	3433	3437
Model	TR2024	TR2424L	TR2430L	TR3024	TR3030	TR3036	TR3636
Size	2024	2424	2430	3024	3030	3036	3636
Stroke	2.25"	2.50"	2.50"	2.50"	2.50"	2.50"	3.00"
P/N Combination	3420051	3427051	3429051	3434051	3430051	3433051	3437051
P/N Single/Piggyback	3420001	N/A	N/A	3434001	3430001	N/A	3437001
P/N Piggyback Plus Kit	N/A	3427008	3429008	N/A	3430008	3433008(a)	3437008
Wt. Combination (Lbs.)	15.9	16.6	18.5	18.3	20.0	26.5	30.8
Wt. Single (Lbs.)	9.6	9.5	11.6	9.7	11.6	18.3	20.2
A	8.31	8.52	9.04	8.47	9.04	9.86	11.13
B	6.16	6.36	6.91	6.12	6.66	7.52	8.38
C	6.9	7.38	7.38	8.31	8.31	8.31	9.25
D	7.34	7.34	8.21	7.34	8.21	9.18	9.18
E	4.75"						
F	5/8" - 11UNC						
G	5/8" - 18UNF						
Inlets	3/8" - NPTF						
X - Min. (in caged position)	8.00" (b)						

NOTES: (a) This model must be used only in combination with MGM Brakes heavy-duty weld reinforced mounting base or 8-gauge NPC (non-pressure housing).

(b) For Transit and Hendrickson Intraax / Vantraax Suspension applications see the Transit / Special Applications section of the MGM Brakes *Master Catalog* (Form No. 6000ss).

- For Replacement Parts for the above spring brake models, please see Master Catalog.
- Product information and specifications subject to change without notice.

www.MGMBrakes.com

Available from:



A Leader in Truck & Bus Safety—Worldwide.



50 Years of Leadership