

SEE SHEET 2 FOR AXLES 3 AND 4

E-STROKE SENSOR EXTENSION HARNESS CONNECTS DIRECTLY TO CCM FOR APPLICATIONS WITHOUT LINING WEAR. TYPICAL FOR ALL E-STROKE SENSOR INPUTS.

5 AMP FUSE  
 RED: 12/24V DC POWER +  
 BLACK: GROUND-

P30-H ALARM OUTPUT 1 TRACTOR/TRUCK/BUS BRAKE MONITOR WARNING LAMP  
 P31-H ALARM OUTPUT 2 TRACTOR/TRUCK/BUS LINING WEAR WARNING LAMP

P30-B P31-B J30-G J31-G

P20-B J20-M  
 P2-N CONNECTS TO LAPTOP DIAGNOSTIC TOOL  
 P3-N CONNECTS TO SAE J1939 DROP LEG HARNESS

LT GREEN OR BLUE: SAE J1708+  
 ORANGE OR WHITE: SAE J1708-

REVISION HISTORY					
REV	DESCRIPTION	ZONE	ECN NO	DATE	BY
1	ISSUED DRAWING		08-097	5/20/08	DJD
2	CORRECTIONS		08-097-1	10/06/08	CAR
2A	REMOVED P34-B FROM SHEET 3 AND SHEET 2	C5			
2B	MOVED WIRES TO PROPER PIN ON SHEET 3	C5			
2C	CHANGED COLOR OF J1708 SHEET 1	B7			
3	REVISED TO INCLUDE USE OF: 1. GEN 3 PRESSURE TRANSDUCER HARNESS 2. GEN 3 SENSOR HARNESS 3. GEN 3 SENSOR ADAPTER HARNESS		09-039	3/12/09	DJD

- EXTENSION HARNESS LENGTH WILL VARY DEPENDING ON APPLICATION.
- SYSTEM DIAGRAM COVERS APPLICATIONS WITH 1 - 4 AXLES. AXLE 1 AT THE FRONT OF THE VEHICLE. CCM CONFIGURATIONS WILL ACTIVATE/DEACTIVATE AXLE INPUTS AS REQUIRED.
- SEE SHEET 2 FOR AXLE 3 AND 4 COMPONENTS.
- SEE SHEET 3 FOR WIRING SCHEMATIC AND CONNECTION INFORMATION
- POWER HARNESS (ITEM 2) CONFIGURATION WILL VARY BASED ON VEHICLE APPLICATION.

16	WARNING LIGHT ADAPTER HARNESS (OPTIONAL FOR TRACTOR APPLICATIONS)
15	SPRING BRAKE ACTUATOR
14	SERVICE CHAMBER
13	GEN 3 PRESSURE TRANSDUCER HARNESS
12	PRESSURE TRANSDUCER
11	LINING WEAR SENSOR - (supplied by lining manufacturer)
10	LINING WEAR EXTENSION HARNESS
9	E-STROKE SENSOR
8	E-STROKE GEN 3 SENSOR EXTENSION HARNESS
7	WHEEL SENSOR ADAPTER HARNESS (ONLY REQUIRED FOR LINING WEAR APPLICATIONS)
6	SAE J1939 DROP LEG HARNESS (OPTIONAL)
5	SAE J1708 HARNESS (OPTIONAL)
4	WARNING LAMP (OPTIONAL)
3	DIAGNOSTIC HARNESS (OPTIONAL)
2	POWER HARNESS
1	CHASSIS COMMUNICATION MODULE (CCM)

ITEM	DESCRIPTION
PROPRIETARY THIS DRAWING IS THE PROPERTY OF MGM BRAKES, DIVISION OF INDIAN HEAD INDUSTRIES INC. AND IS NOT FOR DISSEMINATION OR DISCLOSURE, IN WHOLE OR IN PART, FOR ANY PURPOSE OTHER THAN THAT FOR WHICH IT IS SUBMITTED, EXCEPT AS AUTHORIZED IN WRITING BY MGM BRAKES.	
UNLESS OTHERWISE SPECIFIED TOLERANCE: .015 ON 2-PLACE DIMS .005 ON 3-PLACE DIMS 1 ON ANGLES ALL DIMENSIONS ARE IN INCHES	
DWN ddemus 5/12/2008 SCALE: NONE SHT 1 OF 3	MODEL: D DESCRIPTION: SYSTEM DIAGRAM GEN 3, 1 - 4 AXLES ELECTRONIC STROKE ALERT CHK MC 5/15/2008 APV TW 5/19/2008
DWG NO: 9230100	REV: 3

REVISION HISTORY					
REV	DESCRIPTION	ZONE	ECN NO	DATE	BY
3					
1	ISSUED DRAWING		08-097	5/20/08	DJD
2	CORRECTIONS		08-097-1	10/06/08	CAR
2A	REMOVED P34-B FROM SHEET 3 AND SHEET 2	C5 B3			
2B	MOVED WIRES TO PROPER PIN ON SHEET 3	C5			
2C	CHANGED COLOR OF J1708 SHEET 1	B7			
3	REVISED TO INCLUDE USE OF: 1. GEN 3 PRESSURE TRANSDUCER HARNESS 2. GEN 3 SENSOR HARNESS 3. GEN 3 SENSOR ADAPTER HARNESS		09-039	3/12/09	DJD

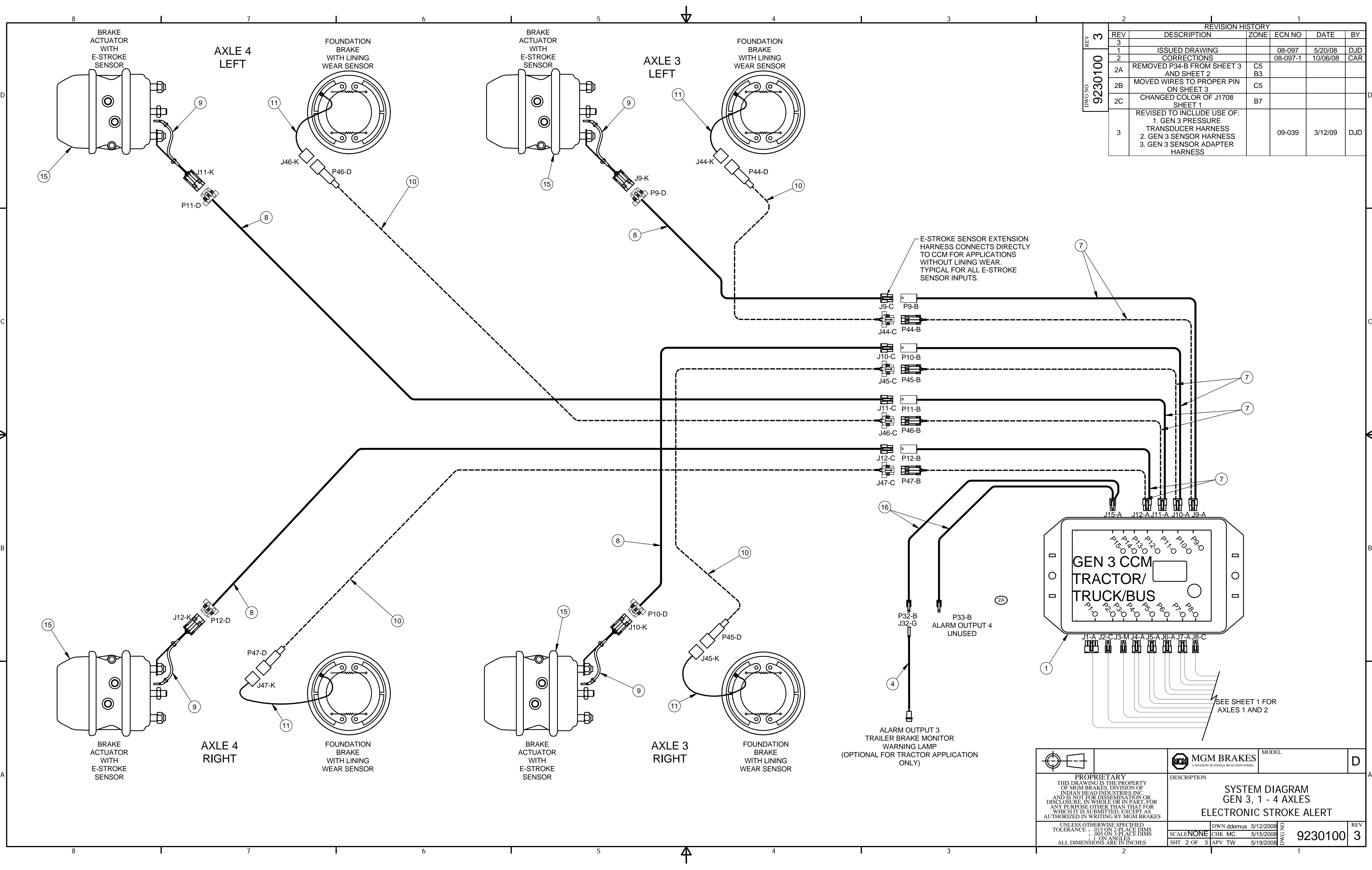

<p>PROPRIETARY THIS DRAWING IS THE PROPERTY OF MGM BRAKES, DIVISION OF INDIAN HEAD INDUSTRIES INC. AND IS NOT FOR DISSEMINATION OR DISCLOSURE, IN WHOLE OR IN PART, FOR ANY PURPOSE OTHER THAN THAT FOR WHICH IT IS SUBMITTED, EXCEPT AS AUTHORIZED IN WRITING BY MGM BRAKES</p>	<p>MGM BRAKES A DIVISION OF INDIAN HEAD INDUSTRIES</p>	MODEL	D
	<p>DESCRIPTION</p> <p>SYSTEM DIAGRAM GEN 3, 1 - 4 AXLES ELECTRONIC STROKE ALERT</p>		
<p>UNLESS OTHERWISE SPECIFIED TOLERANCE: .015 ON 2-PLACE DIMS .005 ON 3-PLACE DIMS 1: ON ANGLES ALL DIMENSIONS ARE IN INCHES</p>	<p>DWN ddemus 5/12/2008</p> <p>SCALE NONE</p> <p>SHT 2 OF 3</p>	<p>CHK MC 5/15/2008</p> <p>APV TW 5/19/2008</p>	<p>REV</p> <p>9230100 3</p>

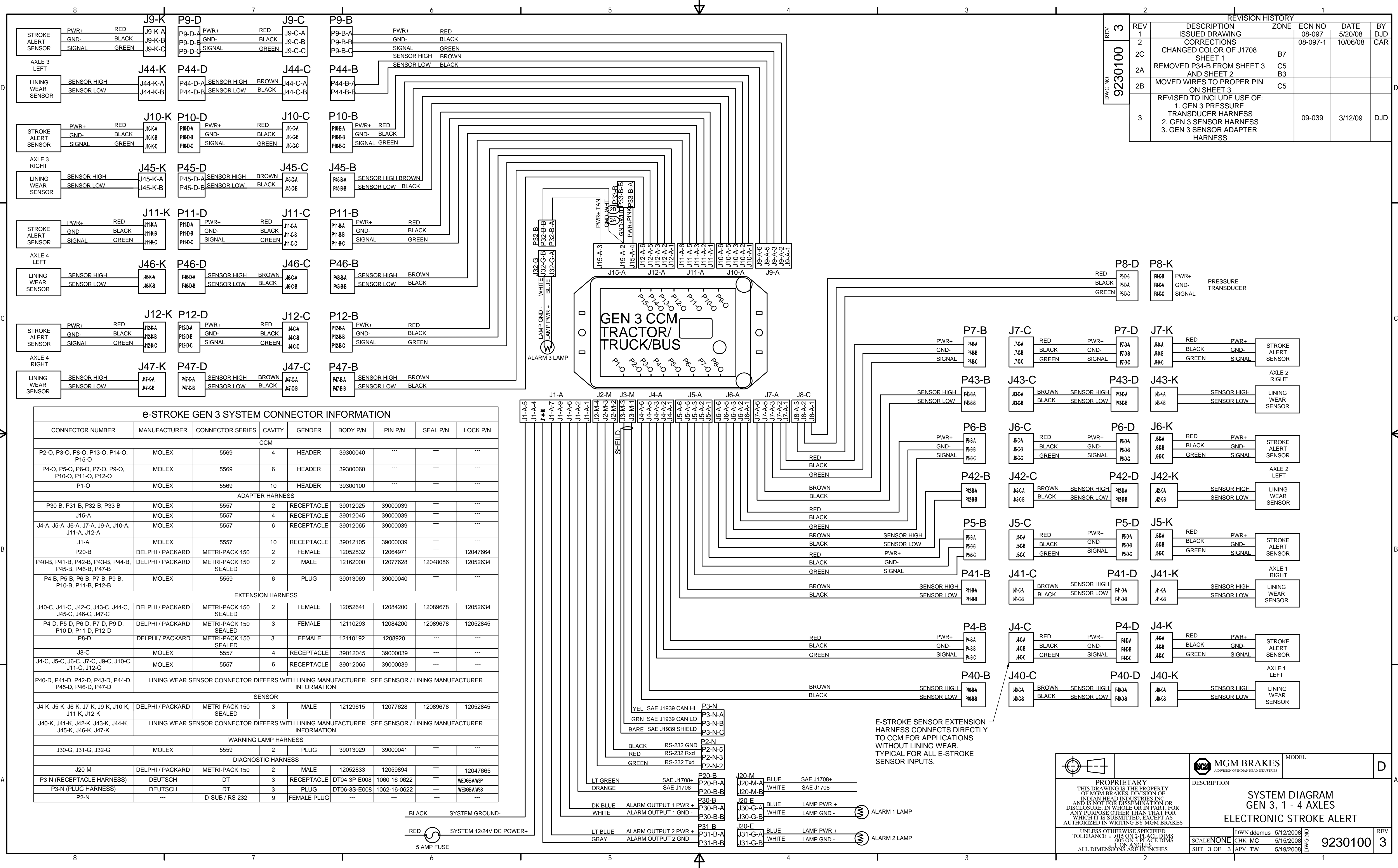

REV		REVISION HISTORY				
REV	DESCRIPTION	ZONE	ECN NO	DATE	BY	
1	ISSUED DRAWING		08-097	5/20/08	DJD	
2	CORRECTIONS		08-097-1	10/06/08	CAR	
2C	CHANGED COLOR OF J1708 SHEET 1	B7				
2A	REMOVED P34-B FROM SHEET 3 AND SHEET 2	C5				
2B	MOVED WIRES TO PROPER PIN ON SHEET 3	C5				
3	REVISED TO INCLUDE USE OF: 1. GEN 3 PRESSURE TRANSDUCER HARNESS 2. GEN 3 SENSOR HARNESS 3. GEN 3 SENSOR ADAPTER HARNESS		09-039	3/12/09	DJD	

**e-STROKE GEN 3 SYSTEM CONNECTOR INFORMATION**

CONNECTOR NUMBER	MANUFACTURER	CONNECTOR SERIES	CAVITY	GENDER	BODY P/N	PIN P/N	SEAL P/N	LOCK P/N
CCM								
P2-O, P3-O, P8-O, P13-O, P14-O, P15-O	MOLEX	5569	4	HEADER	39300040	---	---	---
P4-O, P5-O, P6-O, P7-O, P9-O, P10-O, P11-O, P12-O	MOLEX	5569	6	HEADER	39300060	---	---	---
P1-O	MOLEX	5569	10	HEADER	39300100	---	---	---
ADAPTER HARNESS								
P30-B, P31-B, P32-B, P33-B	MOLEX	5557	2	RECEPTACLE	39012025	39000039	---	---
J15-A	MOLEX	5557	4	RECEPTACLE	39012045	39000039	---	---
J4-A, J5-A, J6-A, J7-A, J9-A, J10-A, J11-A, J12-A	MOLEX	5557	6	RECEPTACLE	39012065	39000039	---	---
J1-A	MOLEX	5557	10	RECEPTACLE	39012105	39000039	---	---
P20-B	DELPHI / PACKARD	METRI-PACK 150	2	FEMALE	12052832	12064971	---	12047664
P40-B, P41-B, P42-B, P43-B, P44-B, P45-B, P46-B, P47-B	DELPHI / PACKARD	METRI-PACK 150 SEALED	2	MALE	12162000	12077628	12048086	12052634
P4-B, P5-B, P6-B, P7-B, P9-B, P10-B, P11-B, P12-B	MOLEX	5559	6	PLUG	39013069	39000040	---	---
EXTENSION HARNESS								
J40-C, J41-C, J42-C, J43-C, J44-C, J45-C, J46-C, J47-C	DELPHI / PACKARD	METRI-PACK 150 SEALED	2	FEMALE	12052641	12084200	12089678	12052634
P4-D, P5-D, P6-D, P7-D, P9-D, P10-D, P11-D, P12-D	DELPHI / PACKARD	METRI-PACK 150 SEALED	3	FEMALE	12110293	12084200	12089678	12052845
P8-D	DELPHI / PACKARD	METRI-PACK 150 SEALED	3	FEMALE	12110192	1208920	---	---
J8-C	MOLEX	5557	4	RECEPTACLE	39012045	39000039	---	---
J4-C, J5-C, J6-C, J7-C, J9-C, J10-C, J11-C, J12-C	MOLEX	5557	6	RECEPTACLE	39012065	39000039	---	---
P40-D, P41-D, P42-D, P43-D, P44-D, P45-D, P46-D, P47-D	LINING WEAR SENSOR CONNECTOR DIFFERS WITH LINING MANUFACTURER. SEE SENSOR / LINING MANUFACTURER INFORMATION							
SENSOR								
J4-K, J5-K, J6-K, J7-K, J9-K, J10-K, J11-K, J12-K	DELPHI / PACKARD	METRI-PACK 150 SEALED	3	MALE	12129615	12077628	12089678	12052845
J40-K, J41-K, J42-K, J43-K, J44-K, J45-K, J46-K, J47-K	LINING WEAR SENSOR CONNECTOR DIFFERS WITH LINING MANUFACTURER. SEE SENSOR / LINING MANUFACTURER INFORMATION							
WARNING LAMP HARNESS								
J30-G, J31-G, J32-G	MOLEX	5559	2	PLUG	39013029	39000041	---	---
DIAGNOSTIC HARNESS								
J20-M	DELPHI / PACKARD	METRI-PACK 150	2	MALE	12052833	12059894	---	12047665
P3-N (RECEPTACLE HARNESS)	DEUTSCH	DT	3	RECEPTACLE	DT04-3P-E008	1060-16-0622	---	WEDGE-A-WSP
P3-N (PLUG HARNESS)	DEUTSCH	DT	3	PLUG	DT06-3S-E008	1062-16-0622	---	WEDGE-A-WSS
P2-N	---	D-SUB / RS-232	9	FEMALE PLUG	---	---	---	---

BLACK SYSTEM GROUND-  
 RED 5 AMP FUSE SYSTEM 12/24V DC POWER+

E-STROKE SENSOR EXTENSION HARNESS CONNECTS DIRECTLY TO CCM FOR APPLICATIONS WITHOUT LINING WEAR. TYPICAL FOR ALL E-STROKE SENSOR INPUTS.

<p>PROPRIETARY THIS DRAWING IS THE PROPERTY OF MGM BRAKES, DIVISION OF INDIAN HEAD INDUSTRIES INC. AND IS NOT FOR DISSEMINATION OR DISCLOSURE IN WHOLE OR IN PART FOR ANY PURPOSE OTHER THAN THAT FOR WHICH IT IS SUBMITTED, EXCEPT AS AUTHORIZED IN WRITING BY MGM BRAKES.</p>	<p>MGM BRAKES A DIVISION OF INDIAN HEAD INDUSTRIES</p>	MODEL	D
	<p>DESCRIPTION</p> <p style="text-align:center"><b>SYSTEM DIAGRAM GEN 3, 1 - 4 AXLES ELECTRONIC STROKE ALERT</b></p>		<p>UNLESS OTHERWISE SPECIFIED TOLERANCE: .005 ON 3-PLACE DIMS 1 ON ANGLES ALL DIMENSIONS ARE IN INCHES</p>
<p>SCALE: NONE</p> <p>SHT 3 OF 3</p>	<p>DWN ddemus 5/12/2008</p> <p>CHK MC 5/15/2008</p> <p>APV TW 5/19/2008</p>	<p>9230100</p>	<p>REV 3</p>