

LTR-T

"Long Life"™ Spring Brake



LTR-T "Long Life" Piggyback Warranted for Six (6) Years; Service Brake warranted for Three (3) Years - Unlimited Mileage. Reference MGM warranty policy for completed details.



MGM Brakes

Form No. 5036

Superior Features of the LTR-T

Built to the highest quality standards for dependable performance and long life. The MGM Model LTR-T Spring Brake offers a combination of features that assure maximum performance.

Built-in Manual Release Bolt

Permanently installed, can't get lost. Permits safe, easy release of the actuator to move the vehicle in the absence of air.

Tamper-Resistant Design

Prevents inadvertent disassembly of power spring housing.

Push Rod Air Seal

Nitrile rubber material. Provides maximum protection against air leaks. Nylon guides prevent metal-to-metal wear and stabilize rod travel.

"Stroke Alert" Indicator

Highly visible orange paint on black epoxy-coated push-rod.

Self-Locking Nuts

Always stays tight, eliminates the need for lock washers.

New Heavy-Duty "Long Life" Power Spring

Powerful, reliable. Flexible epoxy coating for corrosion protection.

External Breather Tube

Vents air from the protected service brake chamber to effectively seal out any liquid or solid corrosive airborne contaminants.

Heavy-Duty Diaphragms

Cold weather natural rubber for longer service life and resistance to deterioration. Low temperature range to -65°F. Suitable for extreme operating conditions.

Non-Pressure Chamber

8 gauge embossed steel epoxy-coated for long life.

Center Hole Shield

Permits visual inspections of stroke alert and prevents entry of contaminants.

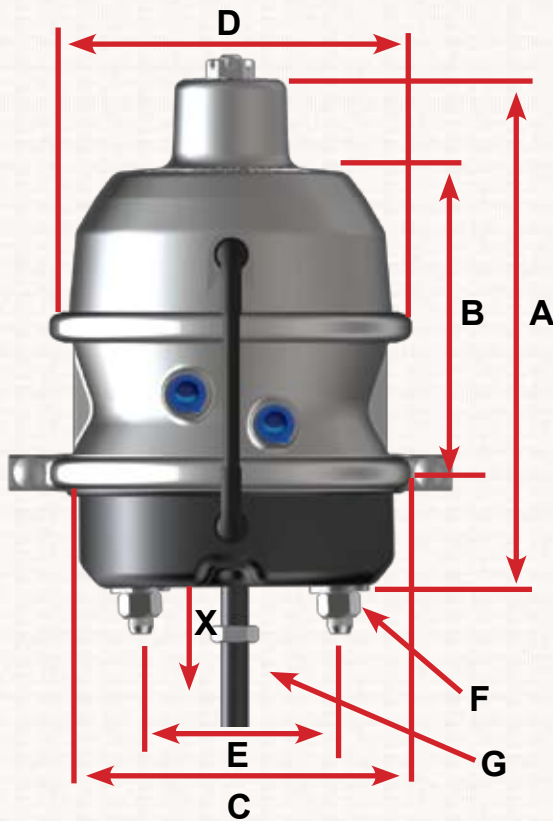
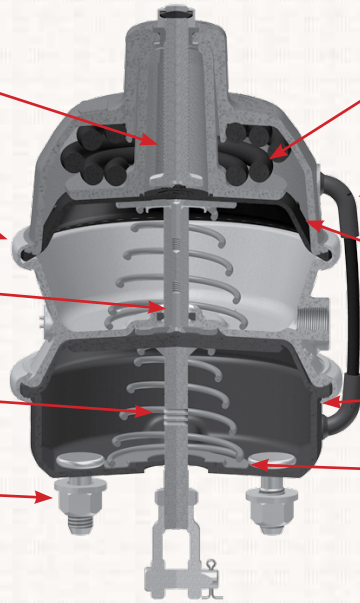

Model	LTR-T	LTR-T
Size	2430L-T	3030-T
Stroke	2.50"	2.50"
P/N Comb.	3827051	3831051
PB + Kit*	3827008	3831008
WT. Comb.	18.5	19.9
WT. Single	11.4	11.7
A	11.8	11.86
B	9.68	9.46
C	7.38	8.27
D	8.18	8.18
E	4.75"	
F	5/8" - 11UNC	
G	5/8" - 18UNF	
Inlets	3/8" - NPTF	
X (Min)	8.00"	

*PB+ Kit includes clamp band and diaphragm.

NOTE: Product information and specifications are subject to change without notice.



A Division of Indian Head Industries, Inc.
www.mgmbrakes.com

Available from:

A Leader in Truck & Bus Safety—Worldwide.