

FEATURES AND BENEFITS

Guaranteed Tough—

Steel and epoxy combine to make the MGM Brakes MAGNUM Performance Plus Spring Brake the most durable you can buy.

MGM Brakes MAGNUM Performance Plus Spring Brakes have a heavy-gauge steel head and a tough double protective coating for long service life. The result is a piston spring brake that is:

- ✓ Impact Resistant
- ✓ Corrosion Resistant
- ✓ Virtually Maintenance-Free

You can count on the MGM Brakes MAGNUM Performance Plus spring brake to perform when you need it most. Compare the benefits and safety features built into the MGM Brakes MAGNUM Performance Plus spring brake against the brakes you're using now.

Compatible with:

- S-Cam Brakes
- Disc Brakes
- Wedge Brakes
- Compact Design: Smaller Diameter, Shorter Height.
- Interchangeable as replacement for other makes of spring brakes.
- Fits in tight areas where some spring brakes can't due to protrusion of release bolt.
- Engineered and built for dependable, trouble-free service on heavy-duty trucks and trailers, even in severe service conditions.
- Manufactured and guaranteed by the world's largest and most experienced spring brake manufacturer.



One "Stop" Shopping at MGM Brakes!



www.MGMBrakes.com
For all your
braking needs!



Form No. 5034 - Rev. 1/2011
©1999 MGM Brakes
All Rights Reserved.
Printed in U.S.A.
A Division of Indian Head Industries, Inc.

Available from:



WHY "PISTON/DIAPHRAGM" BRAKE CHAMBERS?

MJS Series "Piston/Diaphragm" Spring Brakes are designed to provide dependable service for the long haul, as well as withstand the rigors of "stop and go" operations such as emergency response and parcel delivery.

MJS Series Chambers provide fleets with the ability to keep moving, even with an air leak in the spring side of the unit. Unlike diaphragm type spring brakes, which can be rendered inoperable by a minor rupture in the spring side diaphragm, MJS Series piston brakes continue to function, even if the "piston-seal" becomes worn or damaged. This "feature" allows the piston brake to maintain sufficient air pressure to "hold-off" the power spring, allowing the vehicle to complete its route and return home for repair, avoiding the high cost of an "on-the-road" service call. This is a benefit fully recognized by an overwhelming number of transit bus operations, worldwide.

MJS Series Chambers also provide higher parking forces: as much as 502 lbs. more at 1¼ inches of stroke over an equivalent size double-diaphragm model; another benefit recognized by fire truck and emergency vehicle manufacturers and fleet operations throughout North America. These trucks loaded with hoses, ladders and other equipment; along with 500 gallons or more of water, are expected to park and hold on all types of terrain: from U.S. Forest Service mountain roads, to the hills of San Francisco, to the streets of New York. Our MJS Series piston/diaphragm brakes meet these expectations every day.

MJS Series Piston/Diaphragm Spring Brakes: service and dependability you can count on from a name you can trust . . . MGM Brakes.

M A G N U M
Performance Plus

MGM MODEL MJ SERIES

PERFORMANCE CHARACTERISTICS

The world's most advanced spring brake chamber delivers more reliable stopping and parking-force/output power for today's air-braked heavy-duty commercial vehicles. Ideally suited for refuse, ready-mix concrete, school bus and transit fleets.

MAGNUM Performance Plus (MJS Piston Type Model)		
Model Size	Parking Chamber Force Output At 1.25 Inch Stroke Nominal ± 10% lbs.	Hold-Off Pressure (psig) (a)
MJSxx24-ET	1922 lbs.	71
MJSxx28-ET	2320 lbs.	73
MJSxx30-ET	2600 lbs.	75

(a) Hold off pressure measured as decreasing air pressure required to activate spring chamber to within .020" (5 mm) of full "OFF" (deactivated) stroke.

M A G N U M Performance Plus

MGM MODEL MJ SERIES

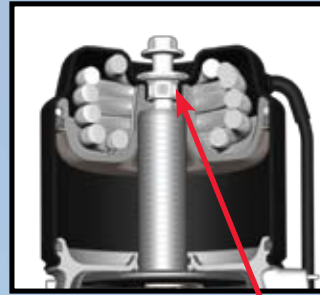
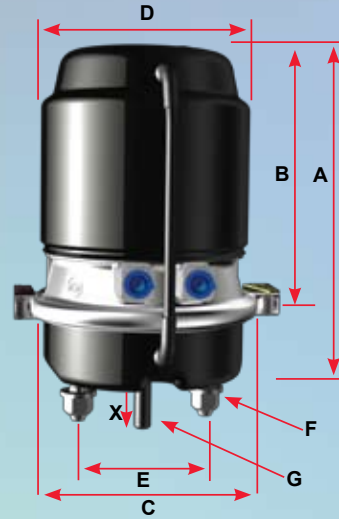

1. Release Bolt
Patented "Dual Thread Release Bolt" design, an MGM Brakes exclusive, provides minimal bolt protrusion at maximum release. (Approx. 1.00 inch (25.4 mm) protrusion when manually released)

**MJS2424ET051
(model shown)**

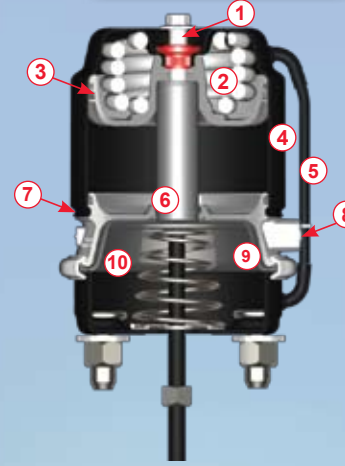

P/N Series	MJS1724ET	MJS2024ET	MJS2030ET	MJS2424ET	MJS2430ET	MJS3024ET	MJS3028ET	MJS3030ET	MJS3628ET	MJS3630ET**
Model	MJS1724ET	MJS2024ET	MJS2030ET	MJS2424ET	MJS2430ET	MJS3024ET	MJS3028ET	MJS3030ET	MJS3628ET	MJS3630ET**
Size	1724	2024	2030	2424	2430	3024	3028	3030	3628	3630
Stroke	3.00" (76.2 mm)	3.00" (76.2 mm)	3.00" (76.2 mm)	3.00" (76.2 mm)	3.00" (76.2 mm)	3.00" (76.2 mm)	3.00" (76.2 mm)	3.00" (76.2 mm)	3.00" (76.2 mm)	3.00" (76.2 mm)
P/N Combination SAE	MJS1724ET051	MJS2024ET051	MJS2030ET051	MJS2424ET051	MJS2430ET051	MJS3024ET051	MJS3028ET051	MJS3030ET051	MJS3628ET051	MJS3630ET051
P/N Piggyback Plus Kit SAE	MJS1724ET008	MJS2024ET008	MJS2030ET008	MJS2424ET008	MJS2430ET008	MJS3024ET008	MJS3028ET008	MJS3030ET008	MJS3628ET008	MJS3630ET008
P/N Combination METRIC	MJS1724ET049	MJS2024ET049	MJS2030ET049	MJS2424ET049	MJS2430ET049	MJS3024ET049	MJS3028ET049	MJS3030ET049	MJS3628ET049	MJS3630ET049
Wt. Combination	20.32 lb (9.2 kg)	20.32 lb (9.2 kg)	22.70 lb (10.3 kg)	20.40 lb (9.3 kg)	23.70 lb (10.8 kg)	22.40 lb (10.2 kg)	23.10 lb (10.5 kg)	23.10 lb (10.5 kg)	25.20 lb (11.4 kg)	25.20 lb (11.4 kg)
Wt. Single	13.50 lb (6.1 kg)	13.50 lb (6.1 kg)	14.90 lb (6.8 kg)	13.50 lb (6.1 kg)	16.26 lb (7.4 kg)	14.60 lb (6.6 kg)	14.92 lb (6.8 kg)	14.92 lb (6.8 kg)	14.50 lb (6.6 kg)	14.50 lb (6.6 kg)
A	10.61" (269.5 mm)	10.61" (269.5 mm)	10.99" (279.1 mm)	10.31" (261.9 mm)	10.70" (271.8 mm)	10.33" (262.4 mm)	10.73" (272.5 mm)	10.73" (272.5 mm)	11.06" (280.9 mm)	11.06" (280.9 mm)
B	7.94" (201.7 mm)	7.94" (201.7 mm)	8.43" (214.1 mm)	7.94" (201.7 mm)	8.43" (214.1 mm)	7.94" (201.7 mm)	8.43" (214.1 mm)	8.43" (214.1 mm)	8.43" (214.1 mm)	8.43" (214.1 mm)
C	6.85" (174.0 mm)	6.85" (174.0 mm)	6.85" (174.0 mm)	7.50" (190.5 mm)	7.50" (190.5 mm)	8.32" (211.3 mm)	8.32" (211.3 mm)	8.32" (211.3 mm)	9.40" (238.8 mm)	9.40" (238.8 mm)
D	6.76" (171.7 mm)	6.76" (171.7 mm)	7.50" (190.5 mm)	6.76" (171.7 mm)	7.50" (190.5 mm)	6.76" (171.7 mm)	7.50" (190.5 mm)	7.50" (190.5 mm)	7.50" (190.5 mm)	7.50" (190.5 mm)
E	4.75" (120.7 mm)			4.75" (120.7 mm)						
F	M16 x 1.5 - 6g			5/8" - 11 UNC (M16 x 1.5 - 6g)						
G	5/8" - 18 UNF (M16 x 1.5 - 6g)			5/8" - 18 UNF (M16 x 1.5 - 6g)						
Inlets	3/8" - 18 NPTF (M16 x 1.5 - 6H)			3/8" - 18 NPTF (M16 x 1.5 - 6H)						
X - Min. (in the caged position)	8.00" (203.2 mm)			8.00" (203.2 mm)						

Refers to chart above:

* Units utilize lower parking force power spring for lower hold off pressure.

** MJS3630ET not "3-inch long stroke" unit, readjustment limit 2.25".

Outstanding Performance for Demanding Applications

Product information and specifications subject to change without notice.

1. Release Bolt

Patented "Dual Thread Bolt" design; exclusive to MGM Brakes, provides minimal bolt protrusion at maximum release.

2. "Long Life" Power Spring

Powerful, reliable, non-coil clash design. Heat-fused epoxy-coated for maximum corrosion protection.

3. Piston Seal and Guide Ring

Main seal is molded from specially formulated low temperature (-65°) and oil resistant neoprene to provide long term protection against air leaks. Guide ring is "self-lubricating" for long service life.

4. Steel Head

MGM Brakes "Roll-In" Tamper Resistant design steel head provides high-impact protection and is double-coated for maximum resistance to corrosion.

5. External Breather Tube

Vents air from the inside protected area of the non-pressure chamber to effectively seal out liquid and solid corrosive airborne contaminants.

6. Center Case Push-Rod and Seal

Aluminum push-rod surface is hard coat finished and slightly porous to retain lubricants. New multi-lipped pressure activated seal retains lubrication to ensure a positive air seal at full range of stroke. Newly designed high tech polymer "guide" prevents metal to metal contact and wear from side loading.

7. "Roll-In" Tamper Resistant Design

With the MGM Brakes "Roll-In" Tamper Resistant design, the heavy gauge steel head is permanently "locked" to the rugged, non-corrosive alloy 360 aluminum center case to positively prevent inadvertent disassembly of the power spring housing.

8. Square Air Inlets (Long Stroke Identifier)

Cast into flange case to provide an instant "Long Stroke" identifier that is pronounced and easily detected.

9. Heavy-Duty Diaphragm

Cold weather tested (-40°F/-40°C) natural rubber for long service life and resistance to deterioration.

10. Non-Pressure Chamber

Heavy-duty 8-gauge steel—heaviest gauge in the industry—embossed for added strength. Heat-fused epoxy-coated to protect against rust and corrosion.



7. "Roll-In" Tamper Resistant Design