

# INFORMATION

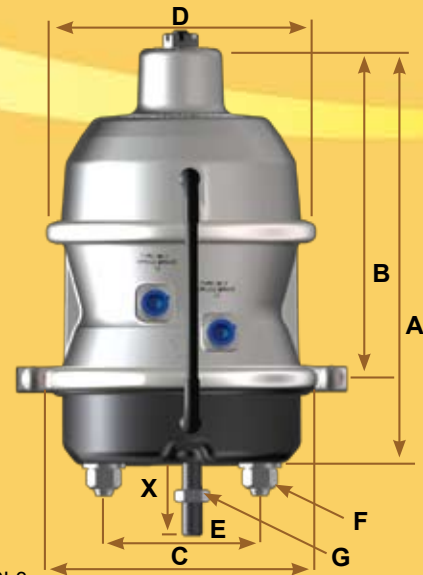

LTR3030L3  
(Model Shown)

## 3" LONG STROKE MODELS

Model	LTR2430L3	LTR3030L3	LTR3030L3T
Size	2430	3030	3030
Stroke	3.00"	3.00"	3.00"
P/N Comb.	3828051	3832051	3833051
PB + Kit*	3828008	3832008	N/A
WT. Comb.	19.3 lbs.	20.5 lbs.	20.5 lbs.
WT. Single	12.3 lbs.	12.6 lbs.	N/A
A	13.0"	13.0"	13.0"
B	10.63"	10.63"	10.63"
C	7.38"	8.27"	8.27"
D	8.18"	8.18"	8.18"
E	4.75"		
F	5/8" - 11UNC		
G	5/8" - 18UNF		
Inlets	3/8" - NPTF		
X (Min)	8.00"		

\*PB+ Kit includes clamp band and diaphragm.

# FORM 5032

*The Leader in Truck & Bus Safety,  
Worldwide.*



## LTR SERIES

LTR-T,  
LTR-L3  
&  
LTR-L3T



[www.MGMBrakes.com](http://www.MGMBrakes.com)

For all your  
braking needs!

**MGM Brakes**  
A Division of Indian Head Industries, Inc.  
8530 Cliff Cameron Drive  
Charlotte, North Carolina 28269  
(704) 547-7411  
(800) 527-1534  
(704) 547-9367 Fax  
[www.mgmbrakes.com](http://www.mgmbrakes.com)  
e-mail: [mail@mgmbrakes.com](mailto:mail@mgmbrakes.com)

Form No. 5032 - Rev. 1/2011  
©1999 MGM Brakes  
All Rights Reserved.  
Printed in U.S.A.  
A Division of  
Indian Head Industries, Inc.

*"Long Life" Spring Brakes*



*For the Long Haul*



Form 5032

# PRODUCT

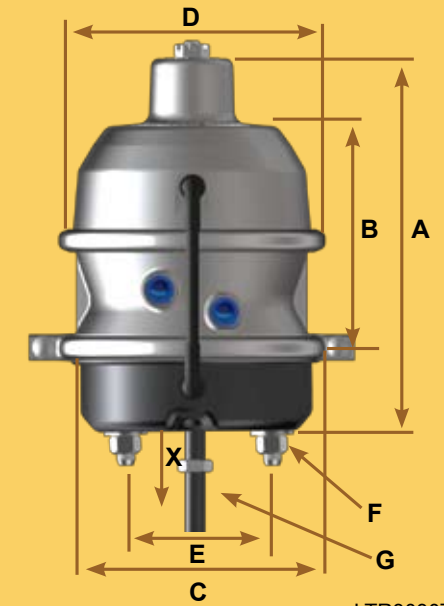

LTR3030T  
(Model Shown)

## STANDARD STROKE MODELS

Model	LTR2430T	LTR3030T
Size	2430	3030
Stroke	2.50"	2.50"
P/N Comb.	3827051	3831051
PB + Kit*	3827008	3831008
WT. Comb.	18.5 lbs.	19.9 lbs.
WT. Single	11.4 lbs.	11.7 lbs.
A	11.80"	11.86"
B	9.68"	9.46"
C	7.38"	8.27"
D	8.18"	8.18"
E	4.75"	
F	5/8" - 11UNC	
G	5/8" - 18UNF	
Inlets	3/8" - NPTF	
X (Min)	8.00"	

\*PB+ Kit includes clamp band and diaphragm.

# LONG LIFE FOR THE LONG HAUL

## EXCLUSIVE FEATURES

LTR3030L3T  
(Model Shown)

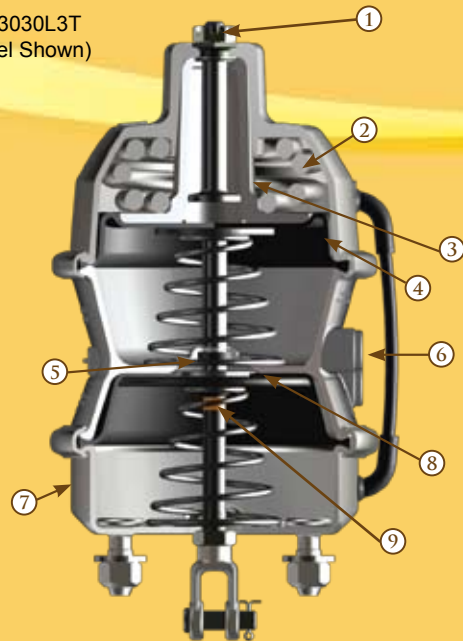

**1. Built-in Manual Release Bolt**  
Permanently installed, can't get lost. Permits safe, easy release of the actuator to move the vehicle in the absence of air. Dacroment™ coated to eliminate corrosion.

**2. "Long Life" Power Spring**  
Powerful, reliable with increased shut height to reduce coil clash. (100 lbs. of additional parking force @ 1.25 inches of stroke).

**3. Low Friction Piston Guide**  
MGM Engineering designed a system that prevents power spring skewing, reduces stress and adds life to the center seal.

**4. Heavy-Duty Diaphragms**  
Cold weather natural rubber for longer service life and resistance to deterioration. Neoprene also available for increased life in oil contaminated environments.

**5. Center Seal**  
Molded nitrile rubber push-rod air seal (not troublesome O-rings) provides maximum protection against air leaks and retains lubricants to extend life. Nylon guides prevent metal-to-metal wear.

**6. Square Air Inlet Ports (Long Stroke Identifier)**  
Cast into flange case to provide an instant long stroke identifier that is pronounced and easily detected. Round on standard stroke.

**7. Non-Pressure Chamber**  
Heavy-gauge formed steel flat-bottom design, epoxy-coated for total corrosion protection. 8 gauge embossed steel on all type 30 service/tandems. 9 gauge on all other sizes.

**8. Centerhole Shield**  
Permits visual inspection of "Stroke Alert" indicator and prevents entrance of stones, dirt, snow, slush and other solid debris.

**9. Stroke Alert Indicator**  
Highly visible orange paint on black epoxy-coated push-rod.

The MGM Model LTR-T and LTR-L3 model spring brakes offer a combination of features that assure maximum performance.

## 3 - INCH LONG STROKE PERFORMANCE CHART

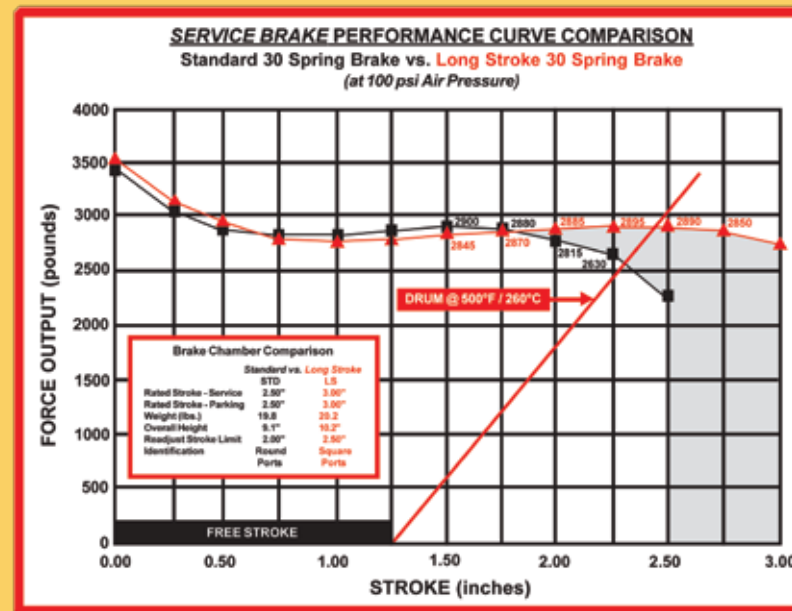

MGM 3-Inch Long Stroke Brakes give you extra stroke for added safety and reliability along with a 6-year warranty\*.

Elevated brake temperatures represent a huge factor in the loss of braking effectiveness and vehicle tests have proven that even though the brakes may be technically in adjustment, stopping distances are greatly influenced by the increased push-rod stroke that results from high drum temperatures.

One sure way to increase the margin of safety for brakes on heavy duty trucks is to lengthen the push-rod stroke of the actuator. MGM Brakes' "Long Life"™ 3-inch Long Stroke chambers can significantly improve braking efficiency and effectiveness by compensating for the heat induced expansion of the brake drum.

Note that the performance curve of the MGM LTR-L3 3-inch Long Stroke chamber (red line) is flatter over the entire stroke compared to the output performance curve of a typical 2½ inch stroke chamber (black line) at 100 psi air pressure. The slanted red line at the end of "free stroke" shows the effect a drum at 500 degrees can have on brake performance.

The National Highway Traffic Safety Administration (NHTSA) has determined that long stroke brakes provide:

- Improved Braking Efficiency
- Increased Reserve Stroke
- Reduced Out-of-Adjustment Citations

\*LTR-L3 "Long Life"™ Piggyback warranted for six (6) years; Service Brake warranted for three (3) years - unlimited mileage. Reference MGM Warranty Policy for complete details.

[www.mgmbreaks.com](http://www.mgmbreaks.com)

Product information and specifications subject to change without notice.



MGM Long Life models are built to the highest quality standards for dependable performance and long life. These MGM model spring brakes offer a combination of features that assure maximum performance. See "Exclusive Features".

## Welded Yoke Units Available

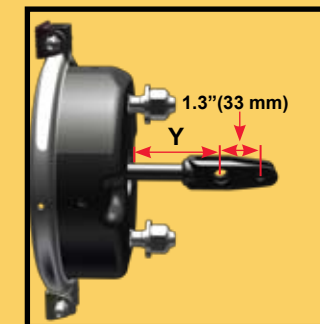

**NOTE:** Type 2430 and 3030 units equipped with welded-yoke and 2.25" (57.2 mm) Y-dimension are replaced by part number:

3828951 (LTR2430L3)  
3832951 (LTR3030L3)

**NOTE:** 3.0625" (77.8 mm) and 4.2" (106.7 mm) Y-dimensions also available. Contact customer service for more information.

Refer to Section 11 of our Master Catalog for replacement parts.

## Weld Reinforced Non-Pressure Housing Available

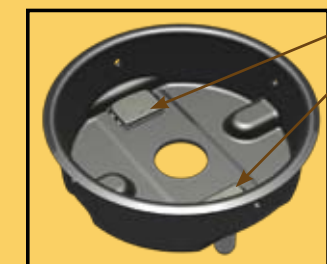

Welded mounting bolts depicted in lighter color for visual purposes.

Available with "weld-reinforced" mounting studs for added support in extreme vibration applications. (bolt actually epoxy coated - depicted here lighter for visual purposes)

- 8-Gauge Standard on Type 3030 & 3036 Aftermarket Models
- 6 Gauge Standard on Type 36 Models

Contact MGM Brakes Customer Service at (800) 527-1534 for more information.