

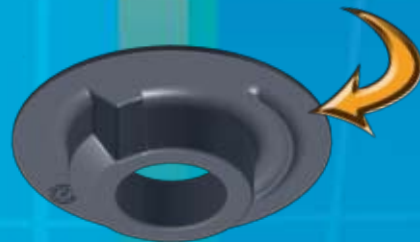

CORROSION — FIGHTER™ — TECHNOLOGY

- ✓ **MGM Spring Brakes** are known for their durability and we are proud that our products already utilize corrosion resistant materials: such as A360 aluminum, epoxy coating and clear trivalent chromate.
- ✓ **Corrosion Fighter Technology** is a "standard" feature in our complete line of Tamper Resistant 3-Inch Long Stroke Model Chambers.
- ✓ The new design also ensures precise alignment of the power spring inside the brake. Accurate alignment of the head side of the power spring compliments our patented Center-Hole Diaphragm (CHD) design: already a standard feature in all TR 3-Inch Long Stroke Models: providing longer center seal and power spring life.



Our full line of Long Stroke Brakes



MGM Brakes
 A Division of Indian Head Industries, Inc.
 8530 Cliff Cameron Drive
 Charlotte, North Carolina 28269
 (704) 547-7411
 (800) 527-1534
 (704) 547-9367 Fax
 www.mgmbrakes.com
 e-mail: mail@mgmbrakes.com



The founders of MGM Brakes set a high standard of quality, innovation and safety over 50 years ago - a philosophy that is woven into the fabric of MGM Brakes. As you learn more about the addition of e•STROKE® to our family of brakes, you will see we are keeping our founders' commitment to our customers and the commercial vehicle industry as we embark on another 50.

Thanks for your continued support for over 50 years. It's been a great ride and we invite you to come along for a SAFE ride with MGM Brakes for the next 50 years and beyond!

Ron Parker

Ron Parker
 Chairman, President and CEO

**LONG STROKE
 BRAKES...
 better than ever!**

LONG STROKE BRAKES...BETTER THAN EVER

MGM TR 3-Inch Long Stroke Brakes give you extra stroke for added safety and reliability.

Elevated brake temperatures represent a huge factor in the loss of braking effectiveness and vehicle tests have proven that even though the brakes may be technically in adjustment, stopping distances are greatly influenced by the increased push-rod stroke that results from high drum temperatures. One sure way to increase the margin of safety for brakes on heavy-duty trucks is to lengthen the push-rod stroke of the actuator. MGM Brakes' family of TR 3-inch Long Stroke chambers can significantly improve braking efficiency and effectiveness by compensating for the heat induced expansion of the brake drum.



MGM TR 3-Inch Long Stroke Spring Brake Chambers are available in a variety of models designed to meet the performance and operational needs of every customer. From the over-the-road hauler to the severe operating environment of refuse collection, MGM has the right model for the toughest jobs.



- Improved Braking Efficiency
- Reduced Incidences of Dragging Brakes
- Reduced Out-of-Adjustment Citations
- Increased Reserve Stroke

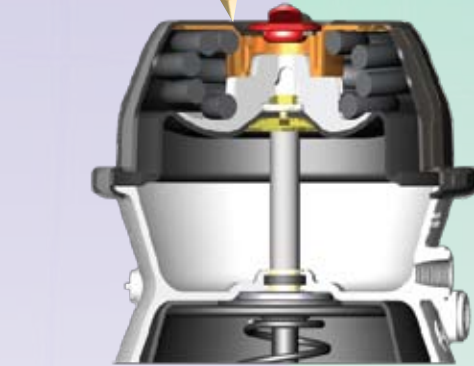
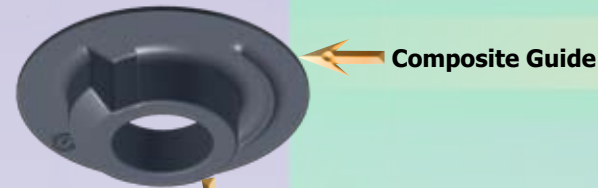

Composite Guide - A Standard Feature
Constructed from heavy-duty, non-metallic composite material. Available on all TR - Long Stroke model chambers. **Note:** guide is depicted in orange for visual purposes.
Patents Pending.

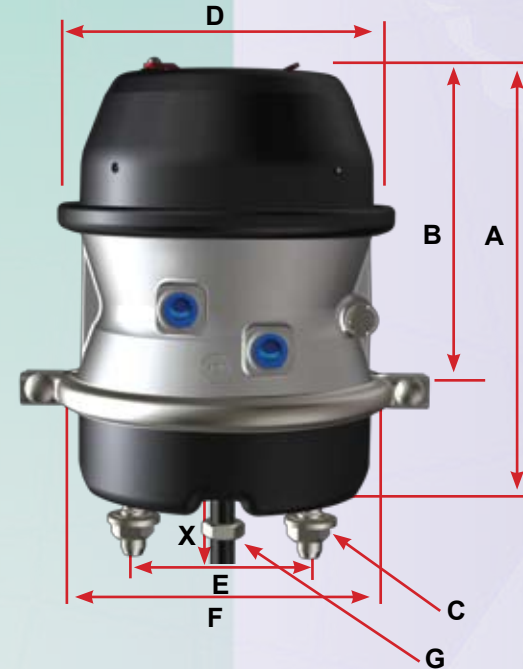

Other standard features include:

"Long Life" Power Spring

Powerful, reliable with increased shut height to reduce coil contact.

Non-Pressure Chamber

Heavy-duty 8 gauge embossed steel on all type 3030 spring brakes.

Center Seal

Nylon guides (not troublesome O-rings) prevent metal to metal wear, ensures alignment and absorbs the load, extending the life of the seal.

Center-Hole Diaphragm

MGM Engineering designed and patented a system that prevents power spring skewing, reduces stress and adds life to the center seal. U.S. Patent #5,507,217.

Heavy-Duty Diaphragms

Cold weather natural rubber for longer service life and resistance to deterioration. Neoprene is also available for increased life in oil contaminated environments.

Size	2030	2430	3030
Stroke - Inches	3.00"	3.00"	3.00"
Wt./Lbs. - Combination	19.1	19.3	20.1
Wt./Lbs. - Single			11.5
A			9.99
B			7.61
C			8.32
D			8.21
E		4.75"	
F		5/8" - 11UNC	
G		5/8" - 18UNF	
Inlets		3/8" - NPTF	
X (Min.)		8.00"	

S-Cam TR3 Long Stroke			Combination	Single/Piggyback Plus Kit**
Model	Size	Stroke	MGM Part No.	MGM Part No.
TR	2030LP3	3.00"	3220051	3220008*
TR	2030LP3T	3.00"	3221051	3221008*
TR	2430LP3	3.00"	3224051	3224008*
TR	2430LP3T	3.00"	3225051	3225008*
TR	2430LP3HD	3.00"	3226051	3226008*
TR	2430LP3THD	3.00"	3227051	3227008*
TR	2430LP3TS	3.00"	3523051	N/A
TR	2430LP3TSHD	3.00"	3527051	N/A
TR	3030LP3	3.00"	3230051	3230008*
TR	3030LP3T	3.00"	3231051	3231008*
TR	3030LP3HD	3.00"	3232051	3232008*
TR	3030LP3THD	3.00"	3233051	3233008*
TR	3030LP3TSHD	3.00"	3534051	N/A
TR	3030LP3TS	3.00"	3535051	N/A

NOTE: (*) Use in combination with MGM Brakes LP3 heavy-duty mounting base only. For 3/4 inch push-rod or transit applications refer to MGM Brakes Master Catalog. Use these models to replace like (long stroke) brake chambers only. (**) "PB+ Kit" includes piggyback chamber, 3-inch long stroke diaphragm and clamp band.

www.mgmbreaks.com

Product information and specifications subject to change without notice.

